

# ISM Band Repeater Demo

**User Guide**  
**Version 2.0r - PRELIMINARY**



Integration Associates, Inc.  
110 Pioneer Way, Unit L  
Mountain View, California 94041

Tel: 650.969.4100  
Fax: 650.969.4582  
[www.integration.com](http://www.integration.com)  
[marketing@integration.com](mailto:marketing@integration.com)  
[techsupport@integration.com](mailto:techsupport@integration.com)

ISM Band Repeater Demo  
User Guide  
Version 2.0r - Preliminary  
Revision Date: December 15, 2005

The information is provided "as is" without any express or implied warranty of any kind, including warranties of merchantability, non-infringement of intellectual property, or fitness for any particular purpose. In no event shall Integration Associates, Inc., or its suppliers be liable for any damages whatsoever arising out of the use of or an inability to use the materials. Integration Associates, Inc., and its suppliers further do not warrant the accuracy or completeness of the information, text, graphics, or other items contained within these materials. Integration Associates, Inc., may make changes to these materials, or to the products described within, at any time, without notice.

© 2005 Integration Associates, Inc. All rights reserved. Integration Associates is a trademark of Integration Associates, Inc. All trademarks belong to their respective owners.

# ABOUT THIS GUIDE

---

The ISM Band Repeater Demo is designed to show the use of Integration's IA4220/IA4221/IA4320/IA4420 chipsets in a multi-transmitter/receiver environment.

For further information on the devices found in this user guide, please visit our Web site: <http://www.integration.com> and download the following datasheets:

<b>IA4220 Universal ISM Band Transmitter datasheet:</b>	<b>IA4220-DS</b>
<b>IA4221 Universal ISM Band Transmitter datasheet:</b>	<b>IA4221-DS</b>
<b>IA4320 Universal ISM Band Receiver datasheet:</b>	<b>IA4320-DS</b>
<b>IA4420 Universal ISM Band Transceiver datasheet:</b>	<b>IA4420-DS</b>

# TABLE OF CONTENTS

---

<b>Demo Kit Contents .....</b>	<b>1</b>
<b>Overview .....</b>	<b>2</b>
<b>Repeater Demo Description .....</b>	<b>4</b>
<b>Demo Unit Table of Contents .....</b>	<b>5</b>
Radio Hardware: IA4220/21 Transmitter Section .....	7
Schematic .....	8
434 MHz Layouts .....	9
915 MHz Layouts .....	10
Radio Hardware: IA4420 Transceiver Section .....	11
Schematic: 50 Ohm Repeater Demo (LCD Version) .....	12
PCB Layout: 50 Ohm Repeater Demo (LCD Version) .....	13
Schematic: 50 Ohm Repeater Demo (Non-LCD Version) .....	14
PCB Layout: 50 Ohm Repeater Demo (Non-LCD Version) .....	15
Radio Hardware: IA4320 Receiver Section .....	17
434 MHz Receiver Schematic .....	18
434 MHz Receiver Layouts .....	19
915 MHz Receiver Schematic .....	20
915 MHz Receiver Layouts .....	21

# DEMO KIT CONTENTS

---

This document describes designs available on the development kit CDROM for the 434 and 915 MHz ISM Repeater Demo. Also covered are the diagrams for both LCD and non-LCD variants. For further details, please refer to [www.integration.com/evaluation\\_kits.php](http://www.integration.com/evaluation_kits.php) or the IA ISM-DKxx CDROM.

IA ISM-UGRP contains the following items:

- Push Button Demo transmitter board
- Two Push Button Demo receiver boards
- Repeater Demo board
- User Guide

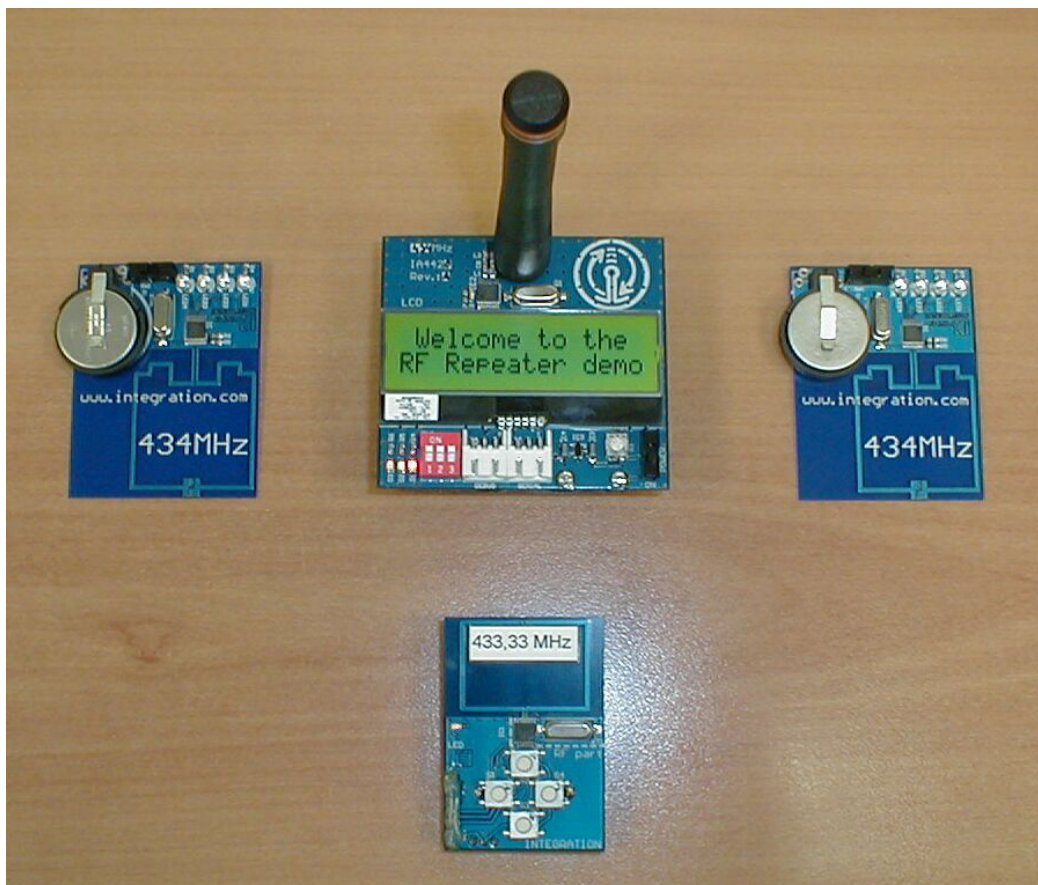

This document is designed to provide as the user guide to all variants of the Repeater Demo. Photographs may differ depending on version. The photograph above is the 434 MHz LCD version.

# OVERVIEW

The demo's main objective is to show the IA4420's capability to monitor multiple frequencies, receive data from an FSK transmitter, and then re-transmit this data on another arbitrary frequency to another receiver or transceiver. This demonstration is designed to show the IA4420 acting as a repeater node.

The Repeater Demo has three main components: the IA4420, which is the system radio, a C8051F311 type 8051 microcontroller, which controls the application, and a 2 line 16 character LCD, which informs the user of the repeater status (Note).

The current version of the Repeater Demo is equipped with a 50 Ohm SMA connector for the antenna.

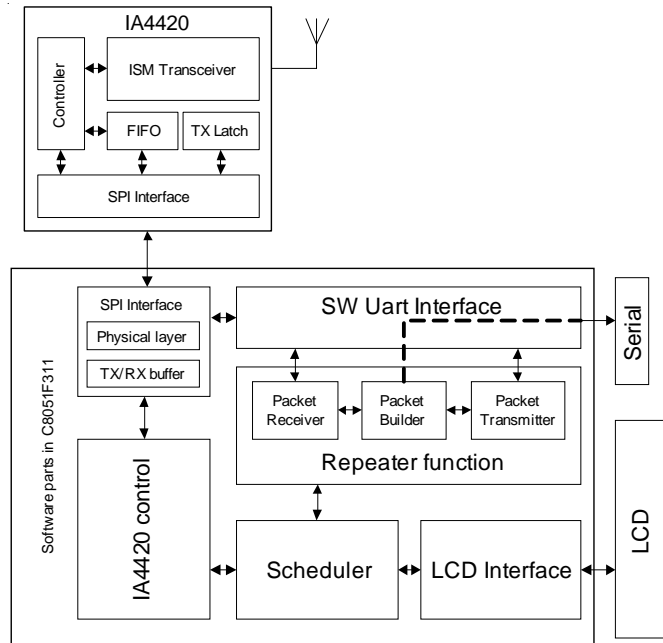
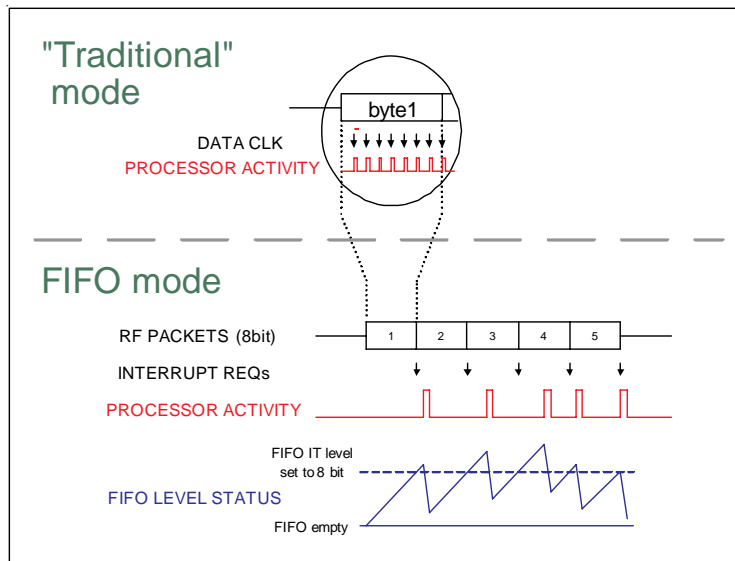

**Fig. 1 Repeater Block Diagram**

**Note:** LCD only available on some models.

# OVERVIEW

The demo uses the developer-friendly features of the IA4420 device. In receive mode the microcontroller reads the received bytes from the IA4420's FIFO, and transmits them through the TX latch. This approach dramatically reduces the load on the micro, because the microcontroller doesn't have to monitor every bit, only the bytes. This means the timing constraints in an application can be reduced at least by a factor of eight for both the transmitting and the receiving sides. See the PROCESSOR ACTIVITY lines on Figure 2, as demonstrated for both the 'Traditional' transceiver mode and the Integration 'FIFO' mode.



**Fig 2. Process Activity in FIFO Mode when Compared to a Traditional Mode of Operation**

# DESCRIPTION

The frequency configuration of this demo is as follows:

- One of the Push Button Demo receivers is set to a different frequency than that of the Push Button transmitter. The other receiver is paired with the frequency of the transmitter.
- The Repeater demo receiving frequency is set to the frequency of the Push Button demo transmitter.

The Repeater demo transmitting frequency is set to the non-paired Push Button demo receiver's frequency

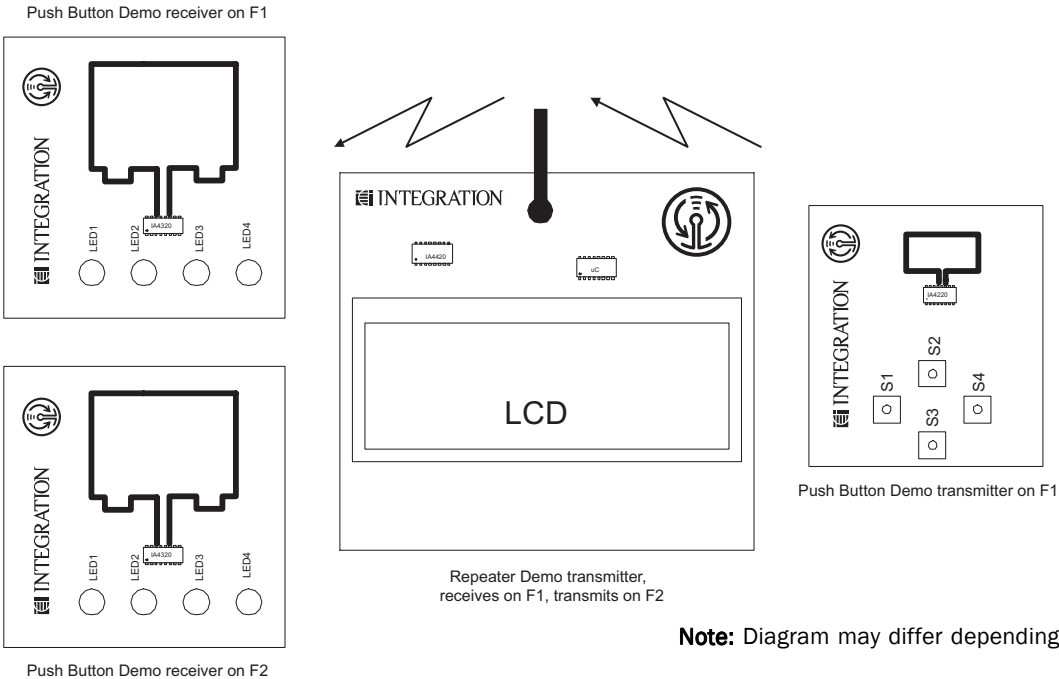

**Fig. 3 Repeater Demo Arrangement**

After power on, the Repeater Demo continually looks for a valid packet on the receiving frequency. This happens when one button has been pressed on the Push Button Demo transmitter. At this moment the LED will light up on the paired Push Button receiver board. After the Repeater Demo (transceiver board) properly receives this packet, it will forward the packet on its transmitting frequency. At that time, the LED will light up on the non-paired Push Button receiver board, if both of the Push Button Transmitter and Push Button Receiver are in the range of the Repeater Demo. It should be noted that the transceiver in this demo adds a small time delay between receiving and transmitting. This is done to prove the transmitter is not talking directly to the receiver. Depending on the button pressed, a different time delay is implemented.

A packet is valid if it contains the preamble bytes (0xAA), the synchron pattern (0x2DD4), and the data, which corresponds to the Push Button Demo data structure.

It can be shown that the paired Push Button demo is working alone, but if the Repeater demo is operating, then both the Push Button Receivers will work, and the RF communication range is significantly bigger than without the Repeater Demo.



# Demo Unit

## TABLE OF CONTENTS

### Radio Hardware

Stage 1 - IA4220 Transmitter

Stage 2 - IA4420 Transceiver

Stage 3 - IA4320 Receiver

*This page is intentionally left blank*

# Radio Hardware

## IA4220/21 TRANSMITTER SECTION

### Contents

- Schematic
- 434 MHz Layouts
- 915 MHz Layouts

# SCHEMATIC: PUSH BUTTON DEMO TX BOARD

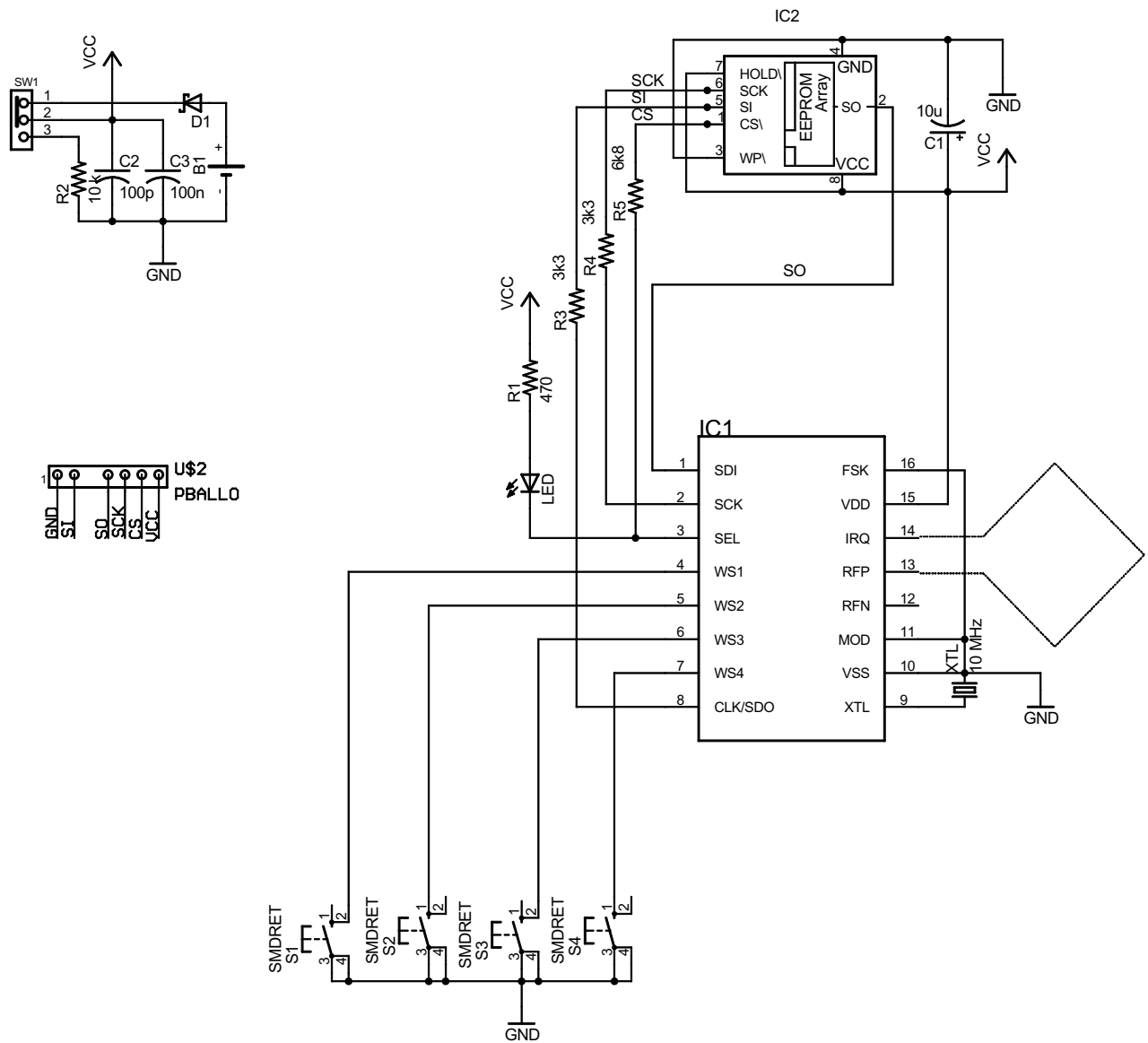

**Fig 4. IA4220 434 MHz Push Button Transmitter Schematic**

Antenna configuration, along with the configuration/frequency setting commands denote operating frequency. Examples of the physical board differences can be seen on the following pages. It can be noted from these layouts that only the antenna is different.

# PCB LAYOUT: 434 MHz PUSH BUTTON TX BOARD



Fig 5. 434 MHz Push Button Transmitter Board PCB Layout



Fig 6. IA4220 434 MHz Push Button Transmitter Board PCB Assembly Layout

# PCB LAYOUT: 915 MHZ PUSH BUTTON TX BOARD

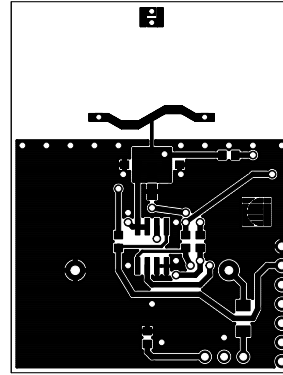
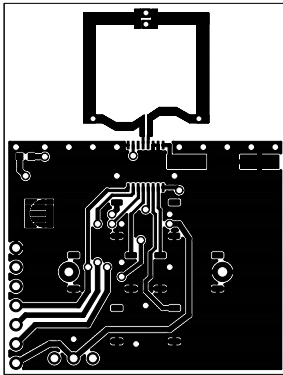

Fig 7. 915 MHz Push Button Transmitter Board PCB Layout

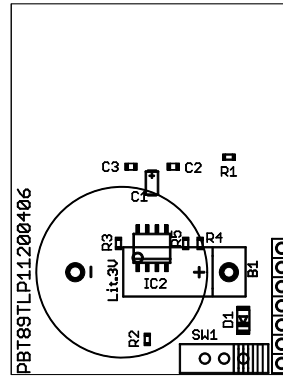
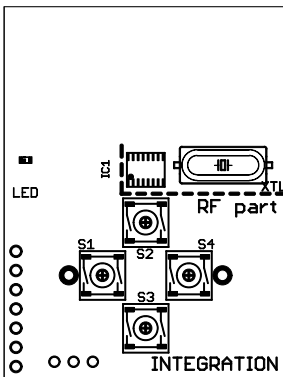

Fig 8. IA4220 915 MHz Push Button Transmitter Board PCB Assembly Layout

# Radio Hardware

## IA4420 TRANSCEIVER SECTION

### Contents

- 50 Ohm Transceiver LCD Board
- 50 Ohm Transceiver Non-LCD Board

# SCHEMATIC: 50 OHM REPEATER DEMO

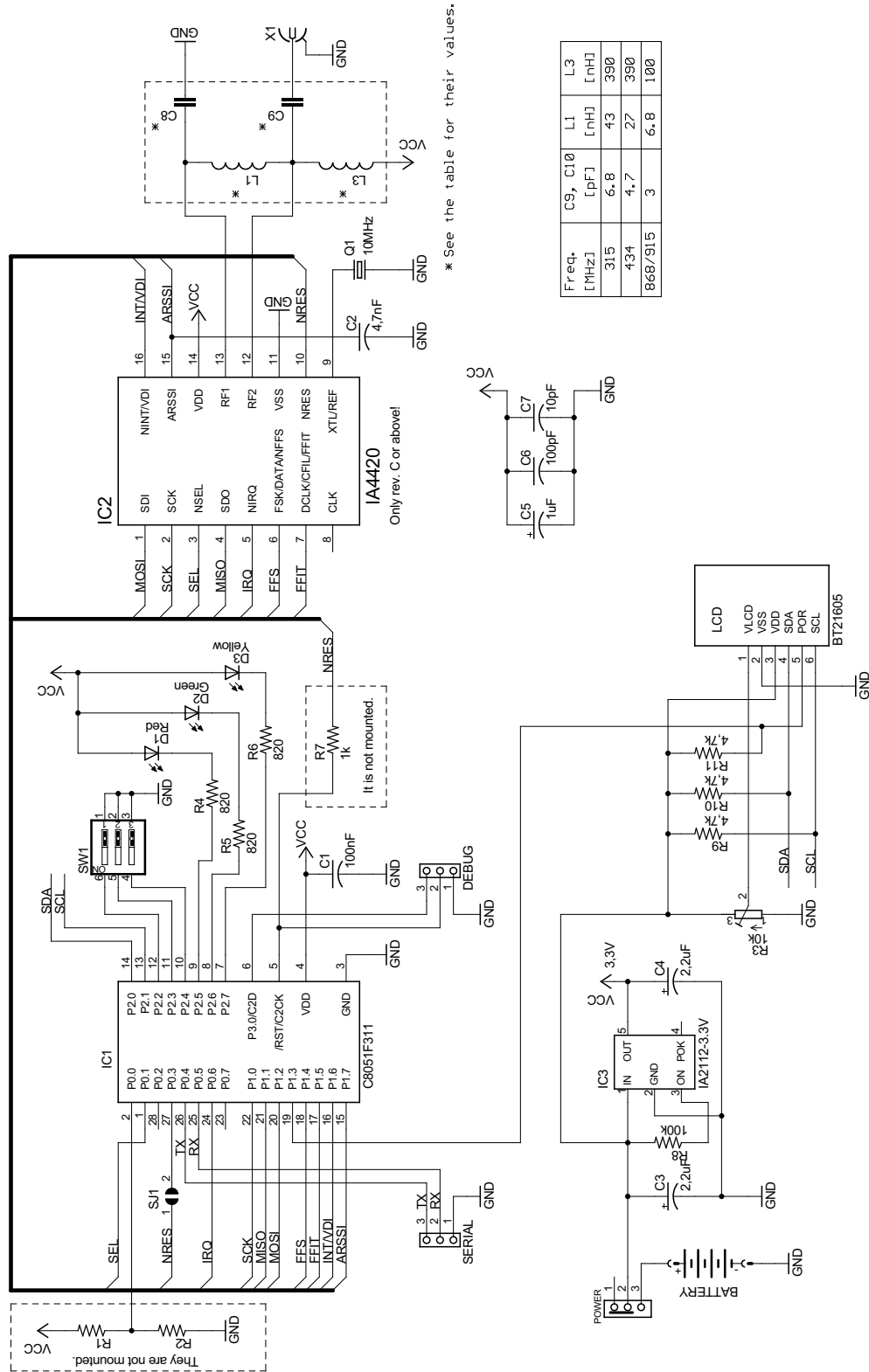

Fig 9 . IA4420 Transceiver Repeater Demo Schematic



# PCB LAYOUT: 50 OHM REPEATER DEMO (LCD VERSION)

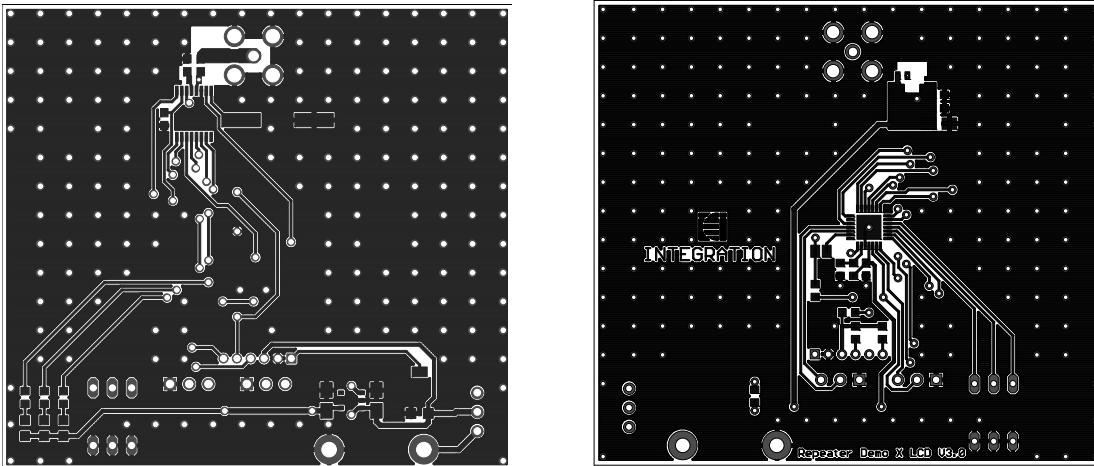

Fig 10. 50 Ohm Repeater Demo PCB Layout

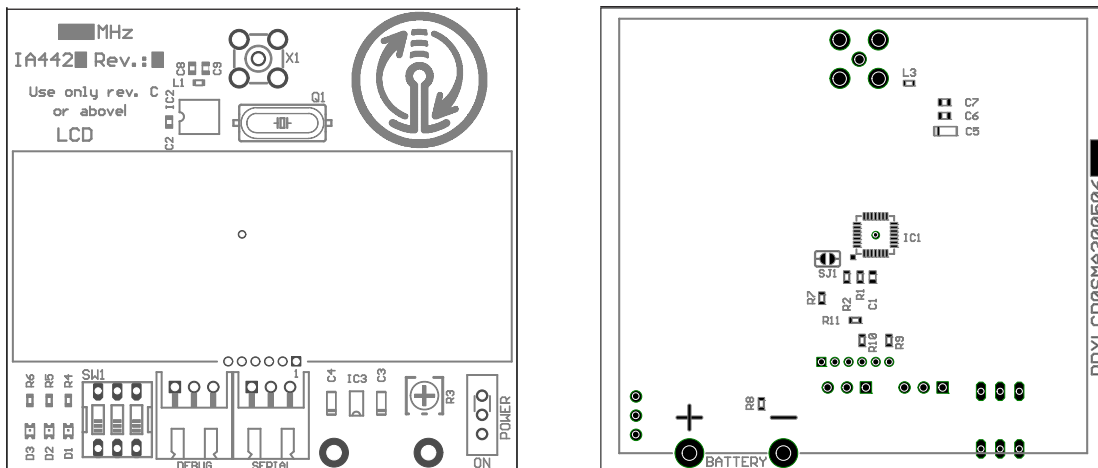

Fig 11. 50 Ohm Repeater Demo IA4420 Transceiver PCB Assembly Layout

# SCHEMATIC: 50 OHM REPEATER DEMO (NON-LCD)

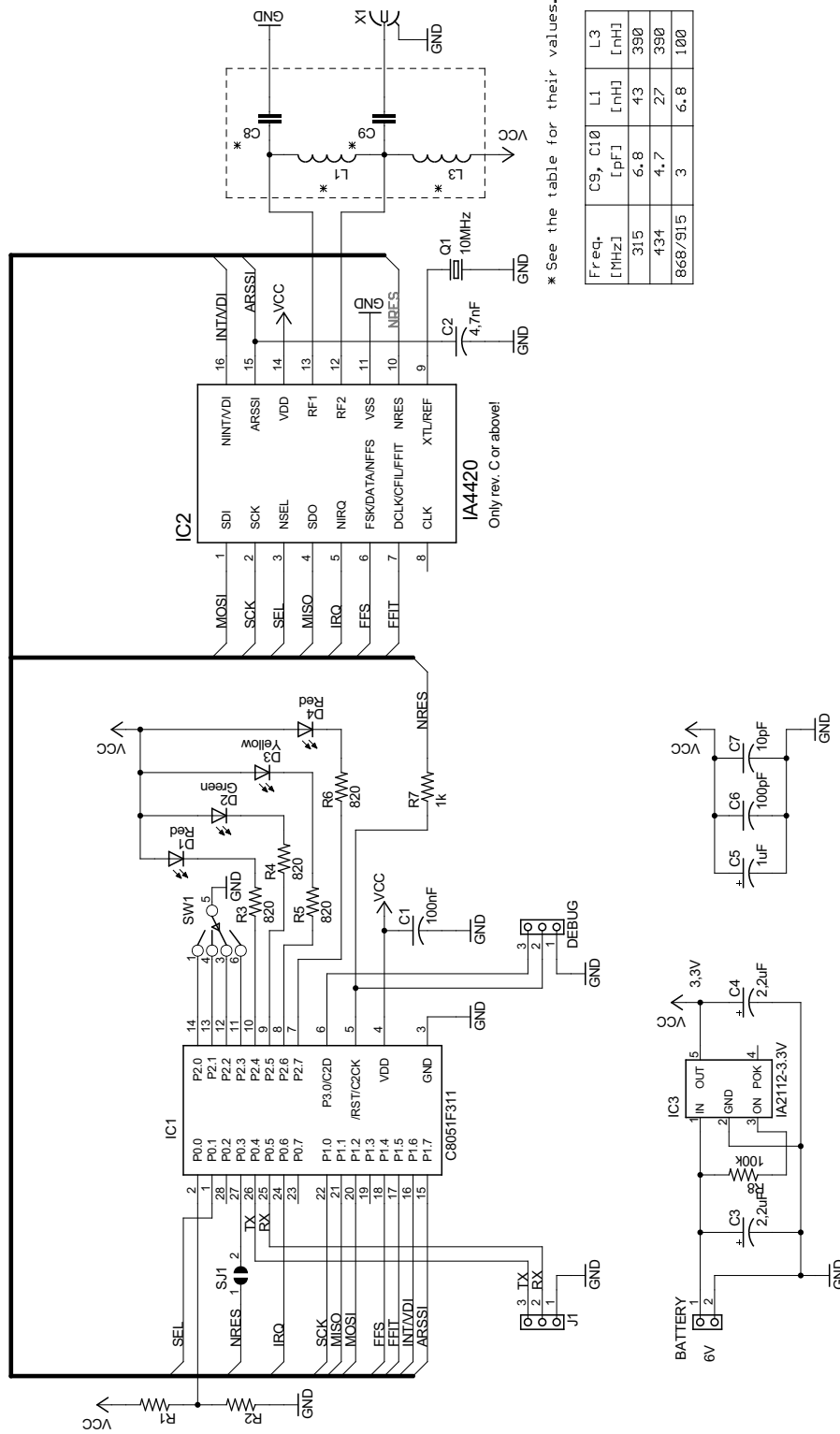
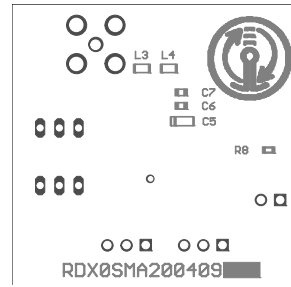
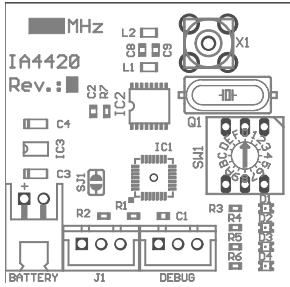
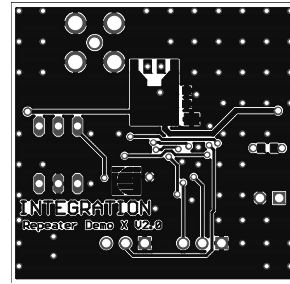
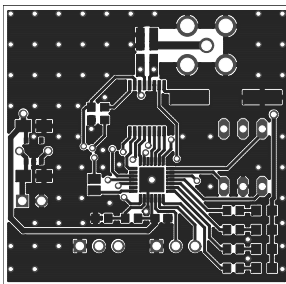

Fig 12. IA4420 Transceiver Repeater Demo Non-LCD Schematic

# PCB LAYOUT: 50 OHM REPEATER DEMO (NON-LCD)



**Fig 13. 50 Ohm Repeater Demo PCB Layout**



**Fig 14 50 Ohm Repeater Demo IA4420 Transceiver PCB Assembly Layout**

*This page is intentionally left blank*

# Radio Hardware

## IA4320 RECEIVER SECTION

### Contents

- Schematic
- 434 MHz Layouts
- 915 MHz Layouts

# SCHEMATIC: 434 MHz PUSH BUTTON RX BOARD

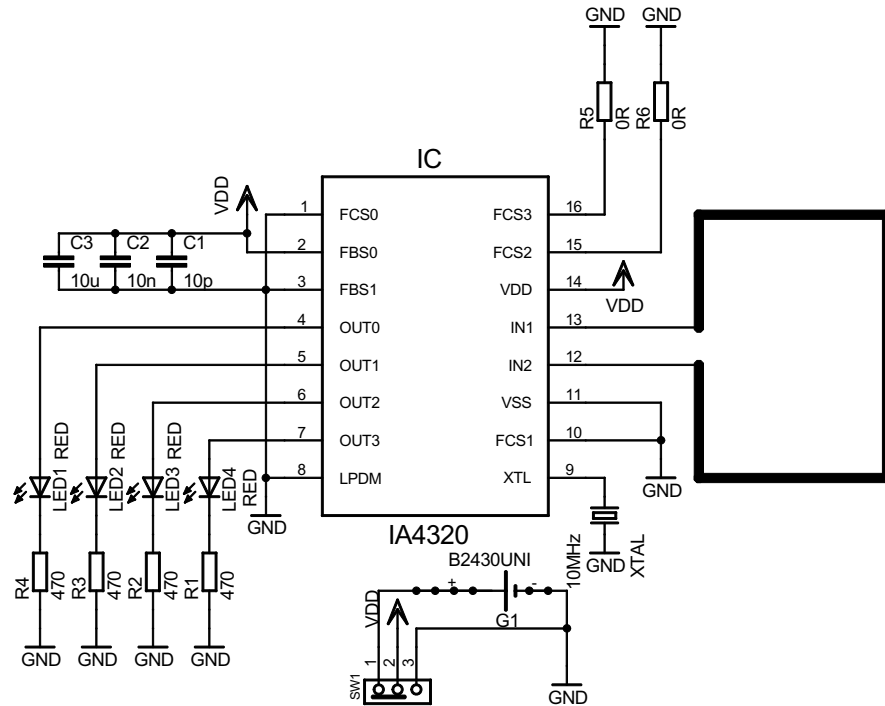

**Fig 15. Example configuration for the 434 MHz IA4320 in Standalone Mode**

Solder resistors R5, R6 according to the following table:

433.36 MHz	R5, R6 = 0 Ohm
434.32 MHz	R5, R6 not present

# PCB LAYOUT: 434 MHz PUSH BUTTON RX BOARD

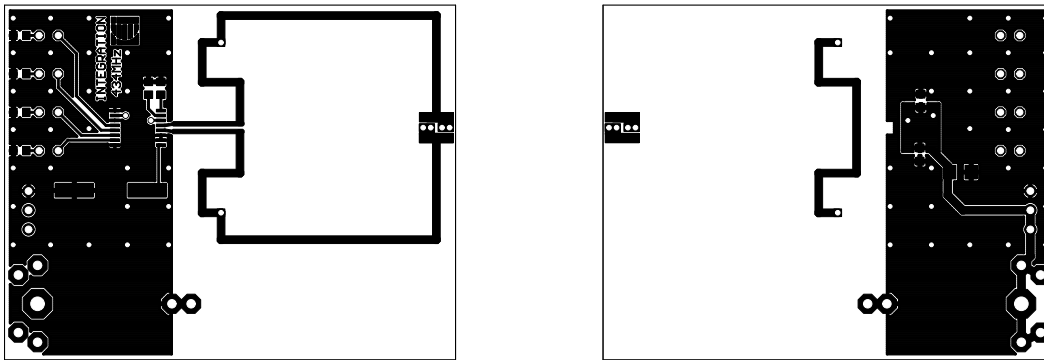

Fig 16. 434 MHz Push Button Receiver Board PCB Layout

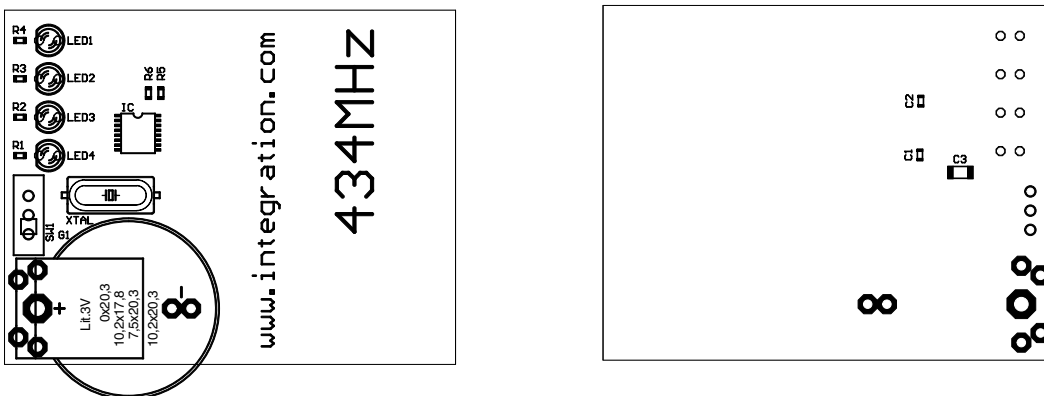

Fig 17. IA4320 434 MHz Push Button Receiver Board PCB Assembly Layout

# SCHEMATIC: 915 MHZ PUSH BUTTON RX BOARD

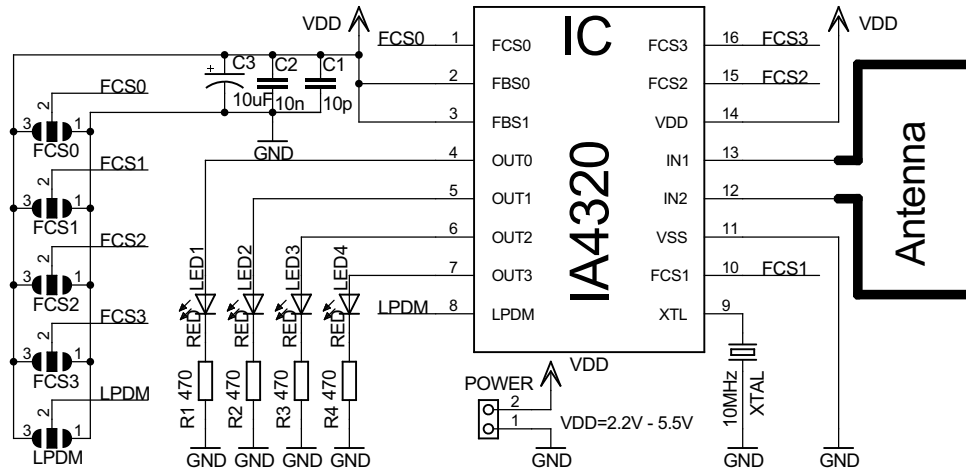

Fig 15. Example configuration for the 915 MHz IA4320 in Standalone Mode

908.64 MHz	LPDM=0, FCS0=0, FCS1=0, FCS2=NC, FCS3=0
916.32 MHz	LPDM=0, FCS0=0, FCS1=0, FCS2=0, FCS3=NC



# PCB LAYOUT: 915 MHZ PUSH BUTTON RX BOARD

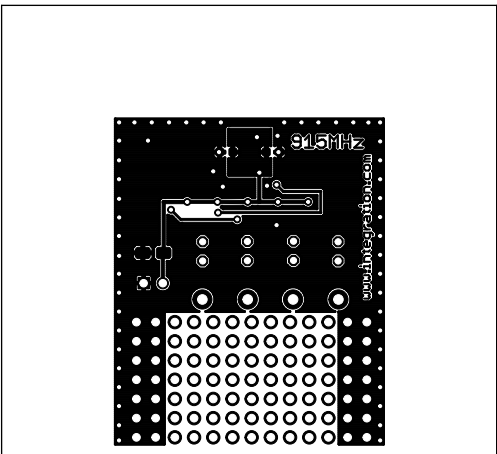
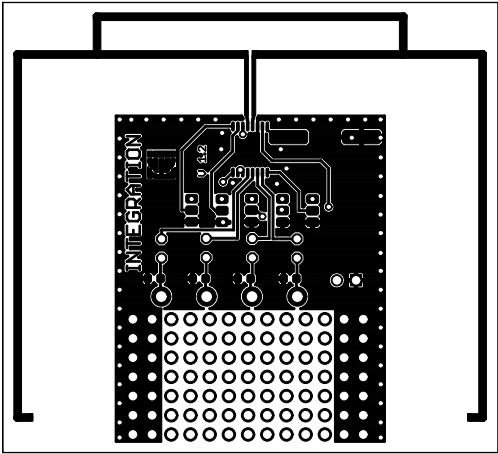

Fig 18. 915 MHz Push Button Receiver Board PCB Layout

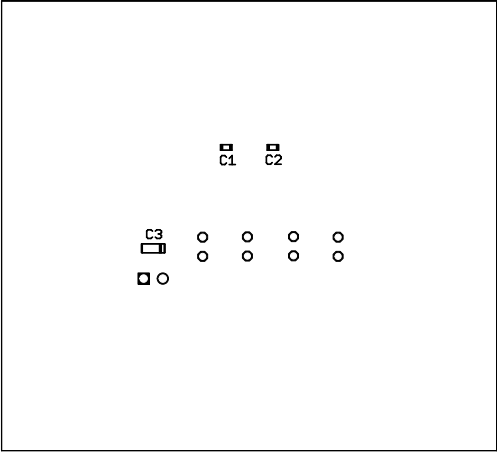
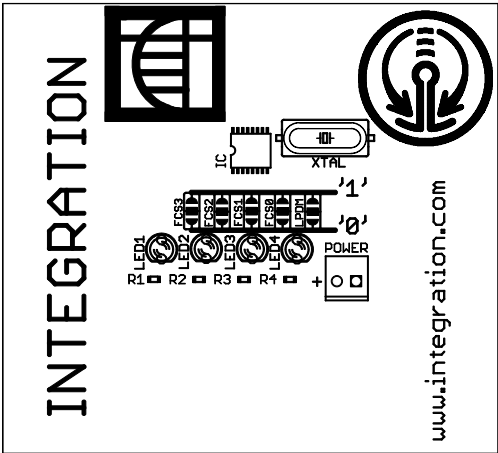

Fig 19. 915 MHz Push Button Receiver Board PCB Assembly Layout

Integration Associates, Inc.  
110 Pioneer Way, Unit L  
Mountain View, California 94041  
Tel: 650.969.4100  
Fax: 650.969.4582  
www.integration.com  
info@integration.com  
techsupport@integration.com

P694

This document may contain preliminary information and is subject to change by Integration Associates, Inc. without notice. Integration Associates assumes no responsibility or liability for any use of the information contained herein. Nothing in this document shall operate as an express or implied license or indemnity under the intellectual property rights of Integration Associates or third parties. The products described in this document are not intended for use in implantation or other direct life support applications where malfunction may result in the direct physical harm or injury to persons. NO WARRANTIES OF ANY KIND, INCLUDING, BUT NOT LIMITED TO, THE IMPLIED WARRANTIES OF MECHANICALITY OR FITNESS FOR A PARTICULAR PURPOSE, ARE OFFERED IN THIS DOCUMENT.

©2005, Integration Associates, Inc. All rights reserved. Integration Associates is a trademark of Integration Associates, Inc. All other trademarks belong to their respective owners.